

**Alpha Bridge SFP  
AQSFP-DD-ZR Datasheet**

# AQSFP-DD-ZR Datasheet



## Features

- QSFP-DD MSA compliant
- Flex-grid channel spacing DWDM in C-band
- Client-side Interfaces: 400GAUI-8
- Line-side DP-16QAM with CFEC
- QSFP-DD type 2A form factor
- RoHS compliant

## Applications

- Data Center Interconnect
- 400G Ethernet
- InfiniBand interconnects
- Enterprise networking

## Description

This product uses a 76-pin QSFP-DD MSA QSFP-DD Hardware Specification connector for all electrical interfaces with the host card, whereas the optical interfaces on the line side are provided through the optical receptacles on the QSFP-DD. The module can be partitioned into three functional parts: TX path, RX path and Control & Power block. The host interface is comprised of a total of 8 high-speed SerDes lanes. This allows module to support one interface for 400G application: an independent double 4-Lane mode client interfaces (for 400GbE application).

## Absolute Maximum Ratings

Parameter	Min.	Typ.	Max.	Units	Notes
Storage Temperature	-40		85	°C	
Storage Humidity (Relative)	0		85	%	no-condensation
Case Temperature	-5		75	°C	
Operating Humidity (Relative)			85	%	no-condensation
Short term Operating Case Temperature			75	°C	
Power Supply Voltage	-0.3		3.63	V	
RX Optical Maximum Input Power			10	dBm	

## Operating Conditions

Parameter	Min.	Typ.	Max.	Units	Notes
Operating Case Temperature			70	°C	
Operating Humidity (Relative)			85	%	no-condensation
Power Supply Operating Range	3.135		3.465	V	

RX Optical Input Power			0	dBm	no-condensation
------------------------	--	--	---	-----	-----------------

### Power Supply Specifications

Parameter	Min.	Typ.	Max.	Units	Notes
3.3V DC Power Supply Voltage	3.135		3.465	V	
3.3V DC Power Supply Current			7	A	
Power Dissipation			18.5	W	
Low Power Consumption			1.0	W	
Module Inrush Current			100	mA/us	
Turn-off Current	-100			mA/us	
Power Supply Noise			25	mV	

### Low Speed Control and Sense Signals

Parameter		Min.	Typ.	Max.	Units	Notes
SCL and SDA	VOL	0		0.4	V	IOL(max)=3 mA for fast mode, 20 mA for Fast-mode plus
	VIL	-0.3		V <sub>CC</sub> * 0.3	V	
	VIH	V <sub>CC</sub> * 0.7		V <sub>CC</sub> + 0.5	V	
Capacitance for SCL and SDA I/O signal	Ci			14	pF	
Total bus capacitive load for SCL and SDA	Ci			100	PF	For 300 kHz clock rate use 3.0kOhms Pill-up resistor, max
				200	pF	For 300 kHz clock rate use 3.0k Ohms Pill-up resistor, max
LPMode, ResetL, ModSelL and ePPS	VIL	-0.3		0.8	V	
	VIH	2		V <sub>CC</sub> + 0.3	V	
LPMode, ResetL and ModSelL	Iin			360	uA	0V < Vin < V <sub>CC</sub>
ePPS	Iin			TBD	pF	0V < Vin < V <sub>CC</sub>
ePPS	VOL			0.4	V	IOL=2.0 mA
	VOH	V <sub>CC</sub> - 0.5		V <sub>CC</sub> + 0.3	V	10k Ohms pull-up tp Host V <sub>CC</sub>
ModPrsL	VOH				V	

### Block Diagram of Transceiver

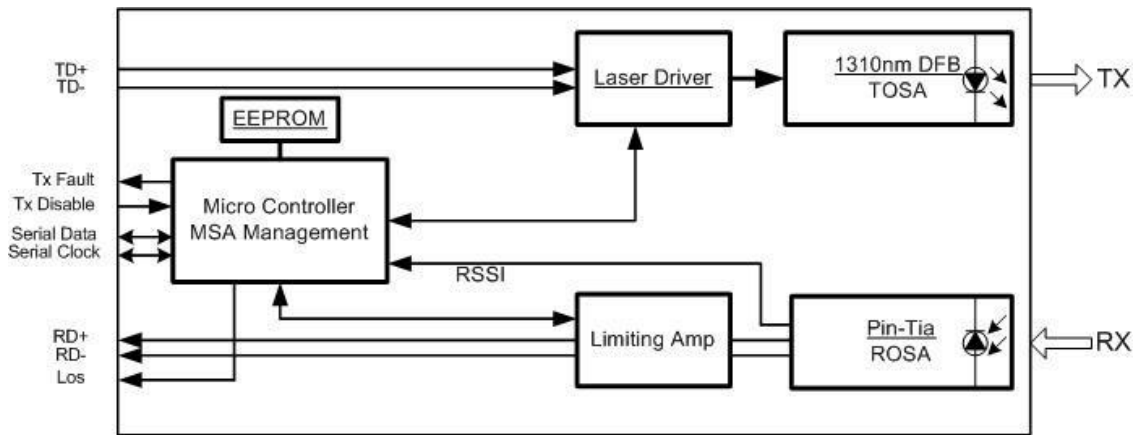

## Optical Characteristics

Parameter	Min.	Typ.	Max.	Units	Note
Transmitter Frequency Range					C band 75GHz ITU-T grid.
	191.3	193.7	196.1	THz	Frequency range over which the specifications hold unless noted otherwise
Laser Frequency Stability	-1.8		1.8	GHz	Frequency stability relative to ITU grid
Laser Frequency Accuracy	-1.8		1.8	GHz	
Laser Frequency Fine Tuning Range	-6.0		6.0	GHz	
Fine Tuning Resolution		100		MHz	
Channel Tuning Speed			60	s	
Laser Line Width			300	kHz	
Transmitter Output Power Range		-11.5		dBm	
Transmitter Output Disable Time			180	ms	
Output Power Stability	-0.5		0.5	dB	Difference over temperature, time, wavelength and aging
Transmitter Turn-up Time from Cold Start			100	s	
Transmitter OSNR (Inband)	34			dB/0.1nm	
Transmitter Back Reflectance			-24	dB	
Transmitter Output Power with TX			-20	dBm	
Disabled					

Transmitter Polarization Dependent Power			1.5	dB	Power difference between X and Y polarization

## Optical Receiver Specifications

Parameter	Min.	Typ.	Max.	Units	Note
Receiver Frequency Range	191.3	193.7	196.1	THz	
Input Power Range	-12		0	dBm	GBd
OSNR Sensitivity			26	dB/0.1nm	mVpp
Receiver Sensitivity	-20			dBm	
Los Assert	-20	-18	-16	dBm	GBd
Los Hysteresis	1.0		2.5	dB	mVpp
CD Tolerance	2400			ps/nm	ps
DGD Tolerance	10			ps	

Parameter	Min.	Typ.	Max.	Units	Note
Peak PDL Tolerance	3.5			dB	Tolerance to peak PDL with < 1.3 dB penalty to OSNR sensitivity when change in SOP is <=1 rad/ms
Tolerance to Change in SOP	50		-	rad/ms	
Input Power Transient Tolerance	-2		2	dB	Tolerance to change in input power with < 0.5 dB penalty to OSNR sensitivity
Input Power Reading Accuracy	-2		2	dB	
Optical Return Loss	-20			dB	Optical reflectance at Rx connector input
Receiver Turn-up Time from Cold Start	-		100	s	From module reset, with valid optical input signal present

## Electronical Characteristics for Transmitter

Parameter	Min.	Typ.	Max.	Units	Note
Signal Rate, each Lane		26.5625±100ppm		GBaud	
Different Peak-Peak Input Voltage Tolerance			900	mVpp	

## Electronical Characteristics for Receiver

Parameter	Min.	Typ.	Max.	Units	Note
Signal Rate, each Lane		26.5625±100ppm		GBaud	

Different Peak-Peak Input Voltage Tolerance		750	900	mVpp	
Transition Time, 20% to 80%		9.5		ps	

## Pin Assignment and Description

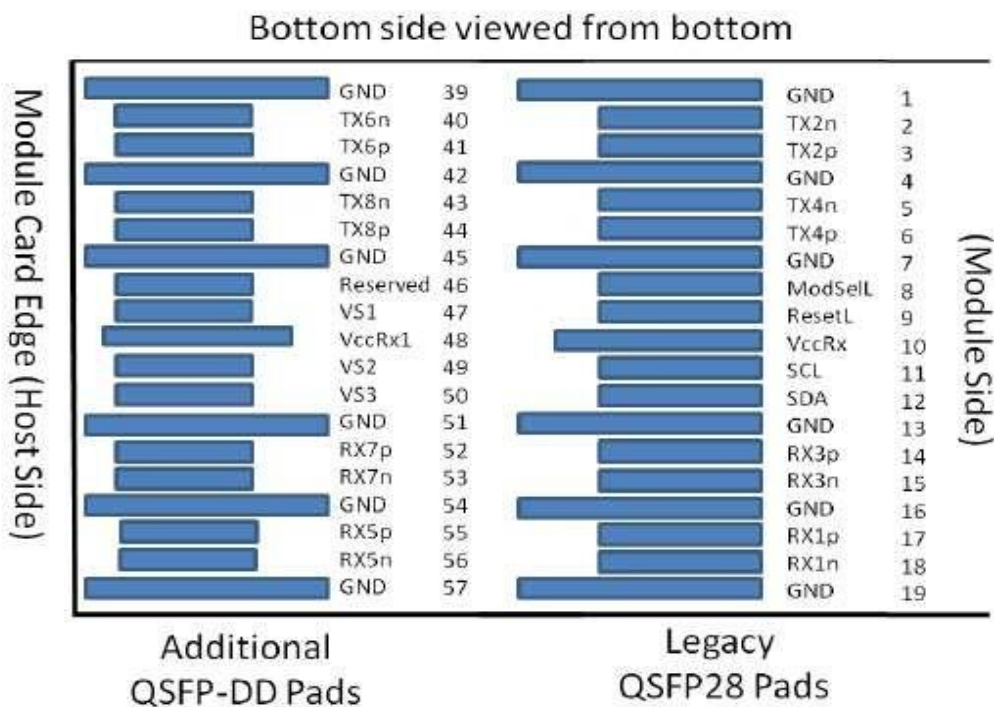
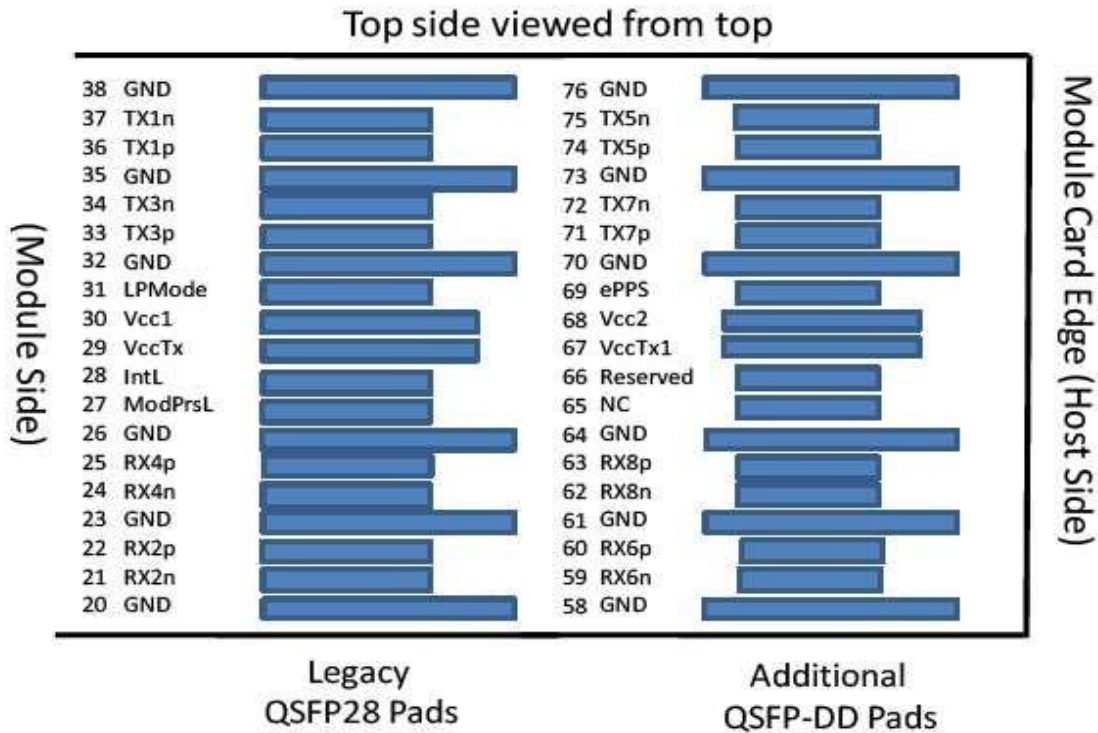

sno	Logic	Symbol	Name/Description	Plug Sequence
1		GND		
2	CML-I	Tx2n	Transmitter Inverted Data Input	3B
3	CML-I	Tx2p	Transmitter Non-Inverted Data Input	3B
4		GND	Ground	1B
5	CML-I	Tx4n	Transmitter Inverted Data Input	3B
6	CML-I	Tx4p	Transmitter Non-Inverted Data Input	3B
7		GND	Ground	1B
8	LVTTL-I	ModSelL	Module Select	3B
9	LVTTL-I	ResetL	Module Reset	3B
10		VccRx	+3.3V Power Supply Receiver	2B
11	LVC MOS-I/O	SCL	2-wire serial interface clock	3B
12	LVC MOS-I/O	SDA	2-wire serial interface data	3B
13		GND	Ground	1B
14	CML-O	Rx3p	Receiver Non-Inverted Data Output	3B
15	CML-O	Rx3n	Receiver Inverted Data Output	3B
16	GND	Ground	1B	1
17	CML-O	Rx1p	Receiver Non-Inverted Data Output	3B
18	CML-O	Rx1n	Receiver Inverted Data Output	3B
19		GND	Ground	1B
20		GND	Ground	1B
21	CML-O	Rx2n	Receiver Inverted Data Output	3B
22	CML-O	Rx2p	Receiver Non-Inverted Data Output	3B
23		GND	Ground	1B
24	CML-O	Rx4n	Receiver Inverted Data Output	3B
25	CML-O	Rx4p	Receiver Non-Inverted Data Output	3B
26		GND	Ground	1B
27	LVTTL-O	ModPrsL	Module Present	3B
28	LVTTL-O	IntL	Interrupt	3B
29		VccTx	+3.3V Power supply transmitter	2B
30		Vcc1	+3.3V Power supply	2B

31	LVTTL-I	InitMode	Initialization mode; In legacy QSFP applications, the InitMode pad is called LPMODE	3B
32		GND	Ground	1B
33	CML-I	Tx3p	Transmitter Non-Inverted Data Input	3B
34	CML-I	Tx3n	Transmitter Inverted Data Input	3B
35		GND	Ground	1B
36	CML-I	Tx1p	Transmitter Non-Inverted Data Input	3B
37	CML-I	Tx1n	Transmitter Inverted Data Input	3B
38		GND	Ground	1B
39		GND	Ground	1A
40	CML-I	Tx6n	Transmitter Inverted Data Input	3A
41	CML-I	Tx6p	Transmitter Non-Inverted Data Input	3A
42		GND	Ground	1A
43	CML-I	Tx8n	Transmitter Inverted Data Input	3A
44	CML-I	Tx8p	Transmitter Non-Inverted Data Input	3A
45		GND	Ground	1A
46		Reserved	For future use	3A
47		VS1	Module Vendor Specific 1	3A
48		VccRx1	3.3V Power Supply	2A
49		VS2	Module Vendor Specific 2	3A
50		VS3	Module Vendor Specific 3	3A
51		GND	Ground	1A
52	CML-O	Rx7p	Receiver Non-Inverted Data Output	3A
53	CML-O	Rx7n	Receiver Inverted Data Output	3A
54		GND	Ground	1A
55	CML-O	Rx5p	Receiver Non-Inverted Data Output	3A
56	CML-O	Rx5n	Receiver Inverted Data Output	3A
57		GND	Ground	1A
58		GND	Ground	1A
59	CML-O	Rx6n	Receiver Inverted Data Output	3A
60	CML-O	Rx6p	Receiver Non-Inverted Data Output	3A
61		GND	Ground	1A



62	CML-O	Rx8n	Receiver Inverted Data Output	3A
63	CML-O	Rx8p	Receiver Non-Inverted Data Output	3A
64		GND	Ground	1A
65		NC	No Connect	3A
66		Reserved	For future use	3A
67		VccTx1	3.3V Power Supply	2A
68		Vcc2	3.3V Power Supply	2A
69		Reserved	For Future Use	3A
70		GND	Ground	1A
71	CML-I	Tx7p	Transmitter Non-Inverted Data Input	3A
72	CML-I	Tx7n	Transmitter Inverted Data Input	3A
73		GND	Ground	1A
74	CML-I	Tx5p	Transmitter Non-Inverted Data Input	3A
75	CML-I	Tx5n	Transmitter Inverted Data Input	3A
76		GND	Ground	1A

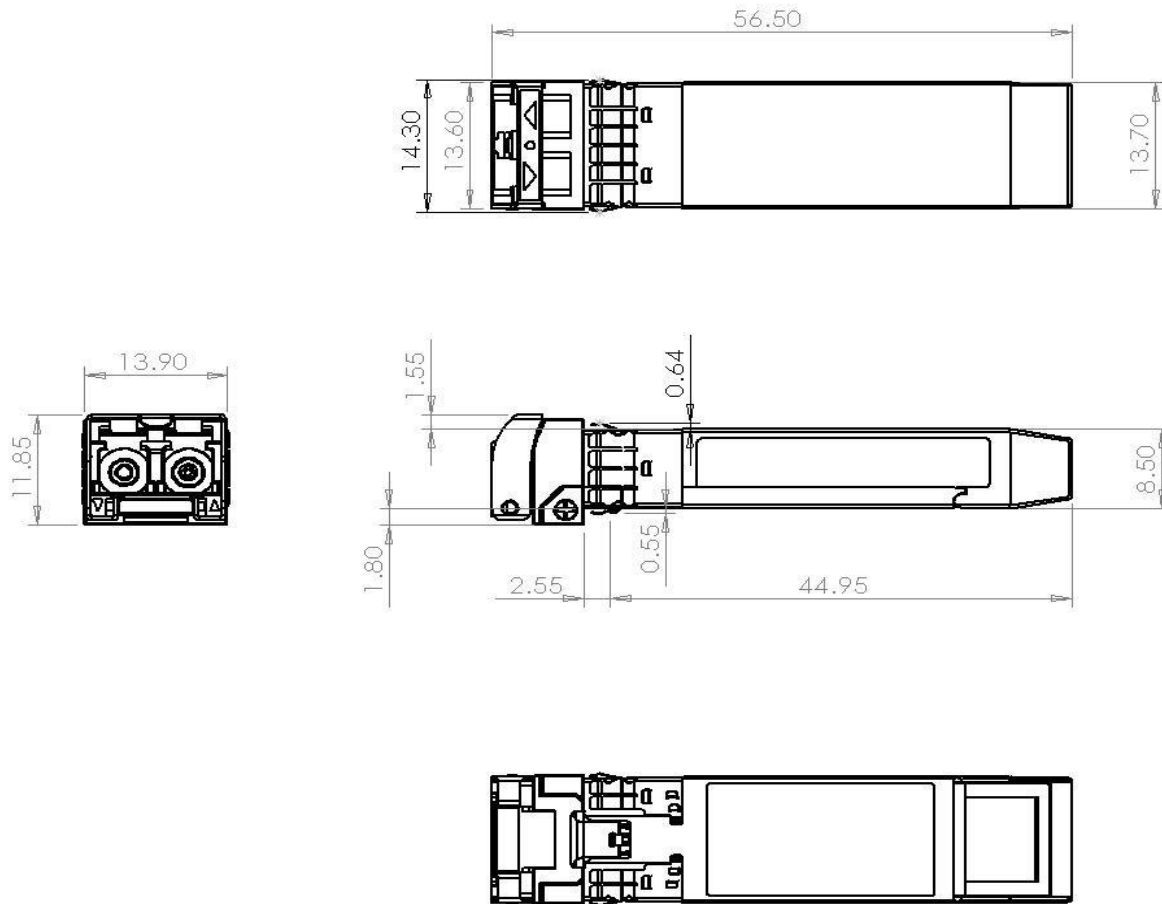

**Optical Receptacle Cleaning Recommendations:**

All fiber stubs inside the receptacle portions were cleaned before shipment. In the event of contamination of the optical ports, the recommended cleaning process is the use of forced nitrogen. If contamination is thought to have remained, the optical ports can be cleaned using a NTT international Cletop® stick type and HFE7100 cleaning fluid. Before the mating of patch-cord, the fiber end should be cleaned up by using Cletop® cleaning cassette.

**Cleaning of patch-cord**



**Cleaning of fiber stub**

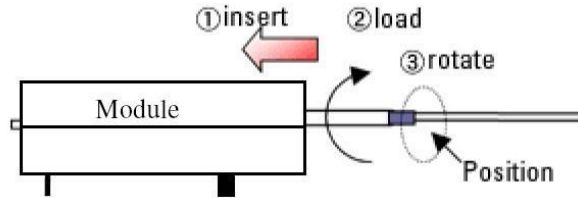

1. Insert  
Ensure that stick is held straight when inserting into sleeve.
2. Load  
Apply sufficient pressure (approx 600-700g) to ensure ferrule a little depressed in sleeve.
3. Rotate  
Rotate stick clockwise 4-5 times, while ensuring direct contact with ferrule end-face is maintained.

*Notice: Number of possible wipes:  
Maintenance (repair) ~1 use / piece  
Equipment construction: 4 uses / piece (max.)*

Note: The pictures were extracted from NTT-ME website. And the Cletop® is a trademark registered by NTT-ME

**Ordering Information**

Model Number	Part Number	Voltage	Temperature
AQSFP-DD-ZR	OPDY-S80-13-CBE	3.3V	0°C to 70°C

**Modification History**

Revision	Date	Description
A1	May 2022	Initial Release

**Note: All information contained in this document is subject to change without notice.**