

Alpha Bridge SFP

AQSFP28-100G-LR4-EML

Datasheet

Description

This product is designed for 10km optical communication applications, and it is compliant to IEEE 802.3ba for 100GE Ethernet. This module contains 4-lane optical transmitter, 4-lane optical receiver and module management block including 2 wire serial interface. The optical signals are multiplexed to a single-mode fiber through an industry standard LC connector.



Features

- QSFP28 MSA compliant
- QSFP28 MSA compliant
- Compliant to IEEE 802.3ba 100GBASE-LR4
- Digital diagnostic monitoring support
- Hot pluggable 38 pin electrical interface
- 4 LAN-WDM lanes MUX/DEMUX design
- 4x25G electrical interface
- Maximum power consumption 4W
- LC duplex connector
- Supports 103.125Gb/s bit rate
- Up to 10km transmission on single mode fiber
- Commercial case temperature range of 0°C to 70°C
- Single 3.3V power supply
- RoHS 2.0 compliant

Application

- 100GBASE-LR4 100G Ethernet
- Telecom networking
- Data Center Interconnect
- Enterprise networking

Absolute Maximum Ratings

Parameter	Symbol	Min.	Max.	Units	Note
Storage Temperature	Ts	-40	85	°C	
Power Supply Voltage	Vcc	-0.5	3.6	V	
Relative Humidity(non-condensation)	RH	5	85	%	1
Damage Threshold, each Lane	THd	5.5		dBm	

Recommended Operating Conditions

Parameter	Symbol	Min.	Max.	Units	Typ.
Supply Voltage	Vcc	3.135	3.465	V	3.3
Case Temperature	Top	0	70	°C	
Link Distance with G.652		0.002	10	km	

Diagnostics Monitoring

Performance Item	Related Bytes(A0[00]memory)	Monitor Error	Notes
Module temperature	22 to 23	+/-3°C	1, 2
Module voltage	26 to 27	< 3%	2
LD Bias current	42 to 49	< 10%	2
Transmitter optical power	50 to 57	< 3dB	2
Receiver optical power	34 to 41	< 3dB	2

Note:

1. Actual temperature test point is fixed on module case around Laser Array.
2. Full operating temperature range

Transmitter Electro-optical Characteristics

Parameter	Symbol	Min.	Typ.	Max.	Unites	Note
Transmit wavelengths		1294.53		1296.59		
		1299.02		1301.09	nm	
		1303.54		1305.63	nm	
		1308.09		1310.19	nm	
Transmitter						
Signaling Speed per Lane			25.78125± 100 ppm		Gb/s	
Side-mode Suppression Ratio(SMSR)	SMSR	30			dB	
Total Average Launch Power				10.5	dBm	
Average launch power, eachLane	P _{AVG}	-4.3		4.5	dBm	

Optical Modulation Amplitude (OMA), each Lane	P_{OMA}	-1.3		4.5	dBm	
Transmitter and Dispersion Penalty (TDP), each lane				2.2	dB	
Extinction Ratio (ER)	ER	4			dB	
Launch power in OMA minus TDP, each lane		-2.3			dBm	
Transmitter Reflectance	R_T			-12	dB	
Transmitter eye mask definition {X1, X2, X3, Y1, Y2, Y3}		{0.25, 0.4, 0.45, 0.25, 0.28, 0.4}				1
Receiver						
Receive wavelengths		1294.53		1296.59	nm	
		1299.02		1301.09	nm	
		1303.54		1305.63	nm	
		1308.09		1310.19	nm	
Signaling Speed per Lane		25.78125± 100 ppm			Gb/s	
Average Receiver Power, each Lane		-10.6		4.5	dBm	
Receiver power, each lane (OMA)				4.5	dBm	
Channel power difference				5.5	dB	
Damage threshold, each lane		5.5			dBm	
Receiver sensitivity (OMA), each lane				-8.6	dBm	2
Stressed receiver Sensitivity (OMA), each lane				-6.8	dBm	2
LOS Assert		-26			dBm	
LOS Dessert				-13	dBm	
LOS Hysteresis		0.5			dB	
Receiver reflectance				-26	dB	
Vertical eye closure penalty, each lane			1.8		dB	
Stressed eye J2 Jitter, each lane			0.3		UI	
Stressed eye J9 Jitter, each lane			0.47		UI	

Notes:

1. Hit ratio 5×10^{-5}
2. Specified at a BER of 10^{-12} , PRBS31

Electrical Characteristics

Parameter	Symbol	Min.	Typ.	Max.	Units	Note
Power Consumption				4	W	
Supply Current	<i>I_{cc}</i>			1.1544	A	Steady-state
Transmitter (each Lane)						
Data Rate, each Lane			25.78125		Gbps	
Differential Input Voltage swing	<i>V_{in, pp}</i>			900	mV	At 1 MHz
Transition time	<i>Trise/Tfall</i>	10			ps	20%~80%
Differential Termination Resistance Mismatch				10	%	
Eye width	<i>EW15</i>	0.46			UI	
Eye height	<i>EH15</i>	95			mV	
Receiver (each Lane)						
Data Rate, each lane			25.78125		Gbps	
Differential output voltage swing	<i>V_{out, pp}</i>			900	mVpp	
Differential Termination Resistance Mismatch				10	%	At 1 MHz
Common Mode Noise, RMS	<i>V_{rms}</i>			17.5	mV	
Transition time	<i>Trise/Tfall</i>	12			ps	20%~80%
Eye width	<i>EW15</i>	0.57			UI	
Eye height	<i>EH15</i>	228			mV	

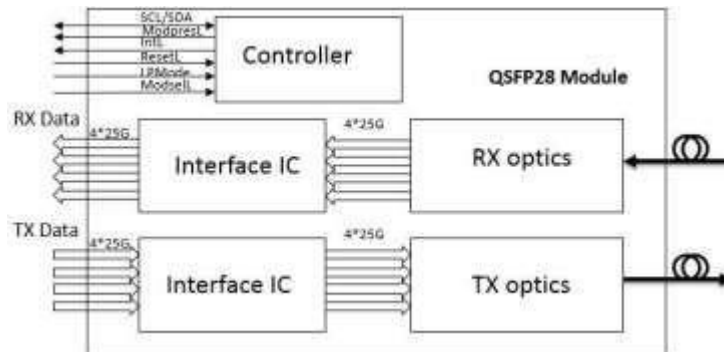
Block Diagram of Transceiver

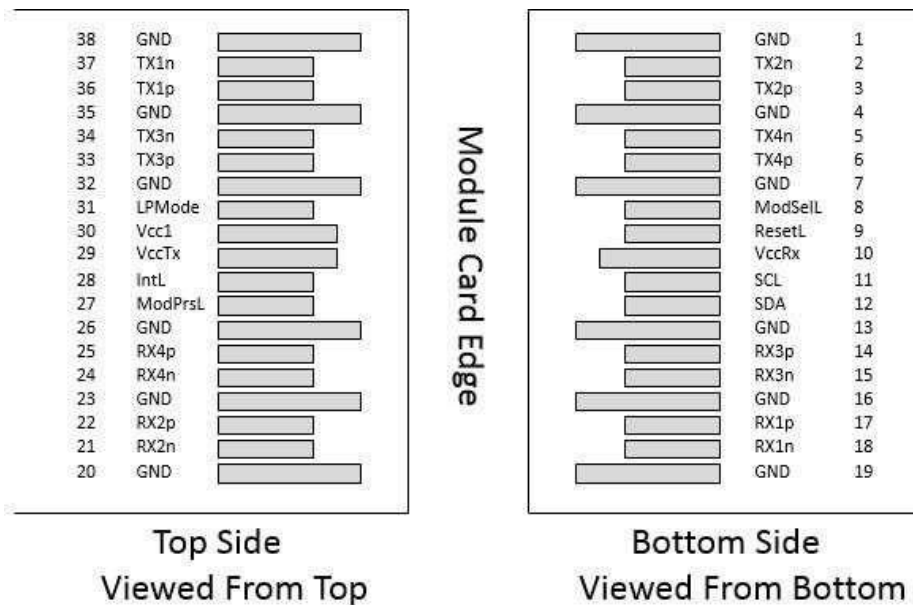

Pin	Symbol	Name/Description	Notes
1	GND	Ground	1
2	Tx2n	Transmitter Inverted Data Input	
3	Tx2p	Transmitter Non-Inverted Data Input	
4	GND	Ground	1
5	Tx4n	Transmitter Inverted Data Input	
6	Tx4p	Transmitter Non-Inverted Data Input	
7	GND	Ground	1
8	ModSelL	Module Select	
9	ResetL	Module Reset	
10	Vcc Rx	+3.3V Power Supply Receiver	
11	SCL	2-wire serial interface clock	
12	SDA	2-wire serial interface data	
13	GND	Ground	1
14	Rx3p	Receiver Non-Inverted Data Output	
15	Rx3n	Receiver Inverted Data Output	
16	GND	Ground	1
17	Rx1p	Receiver Non-Inverted Data Output	
18	Rx1n	Receiver Inverted Data Output	
19	GND	Ground	1
20	GND	Ground	1
21	Rx2n	Receiver Inverted Data Output	
22	Rx2p	Receiver Non-Inverted Data Output	
23	GND	Ground	1
24	Rx4n	Receiver Inverted Data Output	

25	Rx4p	Receiver Non-Inverted Data Output	
26	GND	Ground	1
27	ModPrsL	Module Present	
28	IntL	Interrupt	
29	Vcc Tx	+3.3V Power supply transmitter	
30	Vcc1	+3.3V Power supply	
31	LPMMode	Low Power Mode	
32	GND	Ground	1
33	Tx3p	Transmitter Non-Inverted Data Input	
34	Tx3n	Transmitter Inverted Data Input	
35	GND	Ground	1
36	Tx1p	Transmitter Non-Inverted Data Input	
37	Tx1n	Transmitter Inverted Data Input	
38	GND	Ground	1

Notes:

1. Circuit ground is internally isolated from chassis ground.

Dimensions

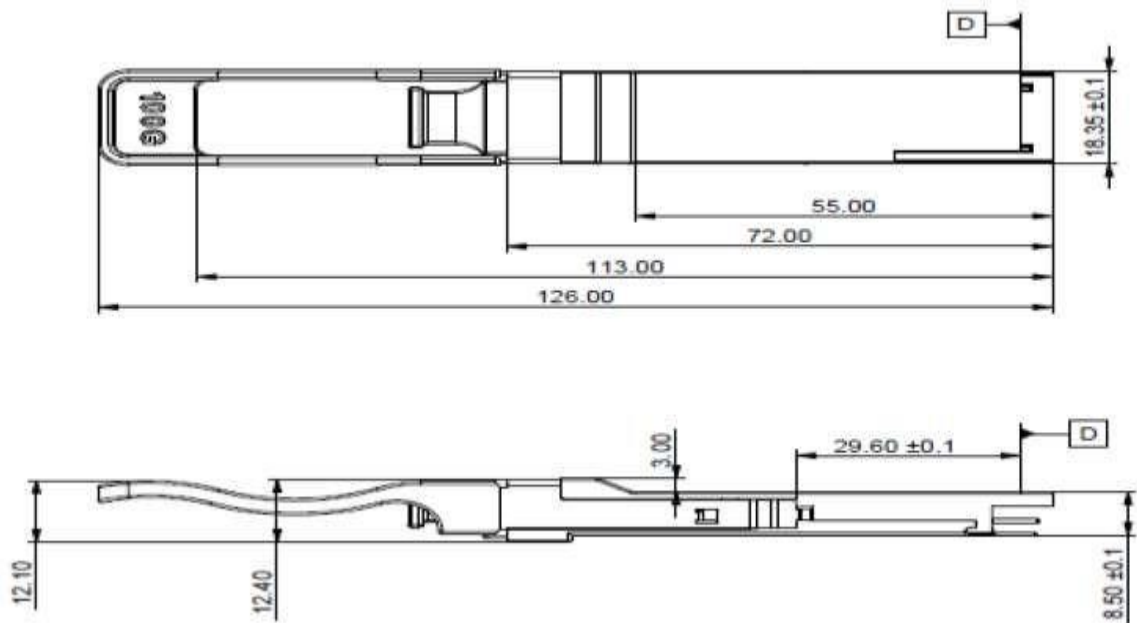

Ordering information:

Model Number	Part Number	Voltage	Temperature
AQSFP28-100G-LR4-EML	OPCW-S40-13-CR	3.3V	0°C to 70 °C

Note: All information contained in this document is subject to change without notice.