

# Alpha Bridge AQSFP28-100G-SR4 Datasheet



### Features

- QSFP28 MSA compliant
- Compliant to IEEE 802.3bm 100GBASE-SR4
- Four independent full-duplex channels
- Supports 103.1Gb/s aggregate bit rate
- Up to 100m OM4 MMF transmission
- Operating case temperature: 0 to 70°C
- Single 3.3V power supply
- 4x25G electrical interface (OIF CEI-28G-VSR)
- Maximum power consumption 2.5W
- MTP/MPO optical connector
- RoHS-6 compliant

### Application

- Rack to Rack
- Data Center
- InfiniBand QDR, DDR and SDR
- 100G Ethernet

### Absolute Maximum Ratings

Parameter	Symbol	Min.	Max.	Units	Note
Storage Temperature	Ts	-40	85	°C	
Power Supply Voltage	Vcc	-0.5	3.6	V	
Relative Humidity(non-condensation)	RH	0	85	%	
Damage Threshold, each Lane	THd	3.4		dBm	
Operating Case Temperature	T <sub>op</sub>	0	70	°C	

### Recommended Operating Conditions

Parameter	Symbol	Min.	Max.	Units	Typ.
Case operating Temperature	T <sub>op</sub>	0	70	°C	
Supply Voltage	Vcc	3.135	3.465	V	3.3
Data Rate, each Lane				Gb/s	25.78125
Data Rate Accuracy		-100	100	ppm	
Pre-FEC Bit Error Ratio			5x10 <sup>-5</sup>		

Post-FEC Bit Error Ratio			1x10 <sup>-12</sup>		1
Control Input Voltage High		2	V <sub>cc</sub>	V	
Control Input Voltage Low		0	0.8	V	
Link Distance (OM3 MMF)	<i>D1</i>		70	m	
Link Distance (OM4 MMF)	<i>D2</i>		100	m	

**Notes:**

1. FEC provided by host system.
2. FEC required on host system to support maximum distance.

**Transmitter Electro-optical Characteristics**

Parameter	Test Point	Min.	Typ.	Max.	Units	Note
Power consumption				2.5	W	
Supply Current	I <sub>cc</sub>			757	mA	
Overload Differential Voltage pk-pk	TP1a	900			mA	
Common Mode Voltage (V <sub>cm</sub> )	TP1	-350		2850	mA	
Differential Termination Resistance Mismatch	TP1			10	%	At 1 MHz
Differential Return Loss (SDD11)	TP1			See CEI-28G-VSR Equation 13-19	dB	
Common Mode to Differential conversion and Differential to Common Mode conversion (SDC11, SCD11)	TP1			See CEI-28G-VSR Equation 13-20	dB	
Stressed Input Test	TP1a	See CEI-28G-VSR Section 13.3.11.2.1				
Center Wavelength	λ <sub>c</sub>	840	850	860	nm	
RMS Spectral Width	Δλ <sub>rms</sub>			0.6	nm	
Average Launch Power, each Lane	PAVG	-8.4		2.4	dBm	
Optical Modulation Amplitude (OMA), each Lane	POMA	-6.4		3	dBm	2
Launch Power in OMA minus TDEC, each Lane		-7.3			dBm	
Transmitter and Dispersion Eye Closure (TDEC), each Lane				4.3	dB	
Optical Return Loss Tolerance	TOL			12	dB	
Average Launch Power OFF, Transmitter, each Lane	P <sub>off</sub>			-30	dBm	

Encircled Flux			$\geq 86\%$ at $19\mu\text{m}$ , $\leq 30\%$ at $4.5\mu\text{m}$			
Extinction Ratio	ER	2			dB	
Transmitter Eye Mask Definition {X1, X2, X3, Y1, Y2, Y3}	{0.3, 0.38, 0.45, 0.35, 0.41, 0.5}					3

### Receiver Electro-optical Characteristics

Parameter	Test Point	Min.	Typ.	Max.	Units	Note
Differential Voltage, pk-pk	TP4			900	mV	
Common Mode Voltage (Vcm)	TP4	-350		2850	mV	1
Common Mode Noise, RMS	TP4			17.5	mV	
Differential Termination Resistance Mismatch	TP4			10	%	At 1MHz
Differential Return Loss (SDD22)	TP4			See CEI-28G-VSR Equation 13-19	dB	
Common Mode to Differential conversion and Differential to Common Mode conversion (SDC22,SCD22)	TP4			See CEI-28G-VSR Equation 13-21	dB	
Common Mode Return Loss, (SCC22)	TP4			-2	dB	
Transition Time, 20 to 80%	TP4	9.5			ps	
Vertical Eye Closure (VEC)	TP4			5.5	dB	
Eye Width at 10-15 probability (EW15)	TP4	0.57			UI	
Eye Height at 10-15 probability (EH15)	TP4	228			mV	
Center Wavelength	$\lambda_c$	840	850	860	Nm	
Damage Threshold, each Lane	THd	3.4			dBm	3
Average Receive Power, each Lane		-10.3		2.4	dBm	
Receive Power (OMA), each Lane				3	dBm	
Receiver Sensitivity (OMA), each lane	SEN			-9.2	dBm	BER=5x10-5

Stressed Receiver Sensitivity (OMA), each Lane				-5.2	dBm	4
Receiver Reflectance	RR			-12	dB	
LOS Assert	LOSA	-30			dBm	
LOS Deassert	LOSD					
LOS Hysteresis	LOSH	0.5			dB	

### Block Diagram of Transceiver

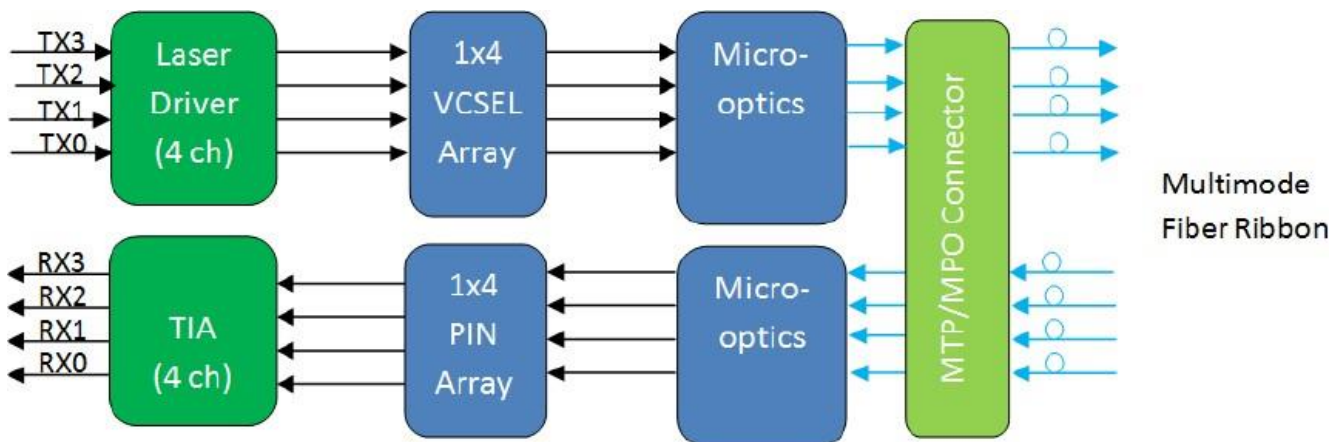

This product is a parallel 100Gb/s Quad Small Form-factor Pluggable (QSFP28) optical module. It provides increased port density and total system cost savings. The QSFP28 full-duplex optical module offers 4 independent transmit and receive channels, each capable of 25Gb/s operation for an aggregate data rate of 100Gb/s on 100 meters of OM4 multi-mode fiber.

An optical fiber ribbon cable with an MTP/MPO connector can be plugged into the QSFP28 module receptacle. Proper alignment is ensured by the guide pins inside the receptacle. The cable usually cannot be twisted for proper channel to channel alignment. Electrical connection is achieved through an MSA-compliant 38-pin edgetype connector.

The module operates by a single +3.3V power supply. LVCMOS/LVTTL global control signals, such as Module Present, Reset, Interrupt and Low Power Mode, are available with the modules. A 2-wire serial interface is available to send and receive more complex control signals, and to receive digital diagnostic information.

Individual channels can be addressed and unused channels can be shut down for maximum design flexibility.

The product is designed with form factor, optical/electrical connection and digital diagnostic interface according to the QSFP28 Multi-Source Agreement (MSA). It has been designed to meet the harshest external operating conditions including temperature, humidity and EMI interference. The module offers very high functionality and feature integration, accessible via a two-wire serial interface.

This product converts parallel electrical input signals into parallel optical signals, by a driven Vertical Cavity Surface Emitting Laser (VCSEL) array. The transmitter module accepts electrical input signals compatible with Common Mode Logic (CML) levels. All input data signals are differential and internally terminated. The receiver module converts parallel optical input signals via a photo detector array into parallel electrical output signals. The receiver module outputs electrical signals are also voltage compatible with Common Mode Logic (CML) levels. All

data signals are differential and support a data rates up to 25Gb/s per channel. Figure 1 shows the functional block diagram of this product.

A single +3.3V power supply is required to power up the module. Both power supply pins VccTx and VccRx are internally connected and should be applied concurrently. As per MSA specifications the module offers 7 low speed hardware control pins (including the 2-wire serial interface): ModSelL, SCL, SDA, ResetL, LPMode, ModPrsL and IntL.

Module Select (ModSelL) is an input pin. When held low by the host, the module responds to 2-wire serial communication commands. The ModSelL allows the use of multiple QSFP28 modules on a single 2-wire interface bus – individual ModSelL lines for each QSFP28 module must be used.

Serial Clock (SCL) and Serial Data (SDA) are required for the 2-wire serial bus communication interface and enable the host to access the QSFP28 memory map.

The ResetL pin enables a complete module reset, returning module settings to their default state, when a low level on the ResetL pin is held for longer than the minimum pulse length. During the execution of a reset the host shall disregard all status bits until the module indicates a completion of the reset interrupt. The module indicates this by posting an IntL (Interrupt) signal with the Data\_Not\_Ready bit negated in the memory map. Note that on power up (including hot insertion) the module should post this completion of reset interrupt without requiring a reset.

Low Power Mode (LPMode) pin is used to set the maximum power consumption for the module in order to protect hosts that are not capable of cooling higher power modules, should such modules be accidentally inserted.

Module Present (ModPrsL) is a signal local to the host board which, in the absence of a module, is normally pulled up to the host Vcc. When a module is inserted into the connector, it completes the path to ground through a

resistor on the host board and asserts the signal. ModPrsL then indicates a module is present by setting ModPrsL to a “Low” state.

Interrupt (IntL) is an output pin. Low indicates a possible module operational fault or a status critical to the host system. The host identifies the source of the interrupt using the 2-wire serial interface. The IntL pin is an open

**collector output and must be pulled to the Host Vcc voltage on the Host board.**

**Pin Assignment (MSA compliant connector)**

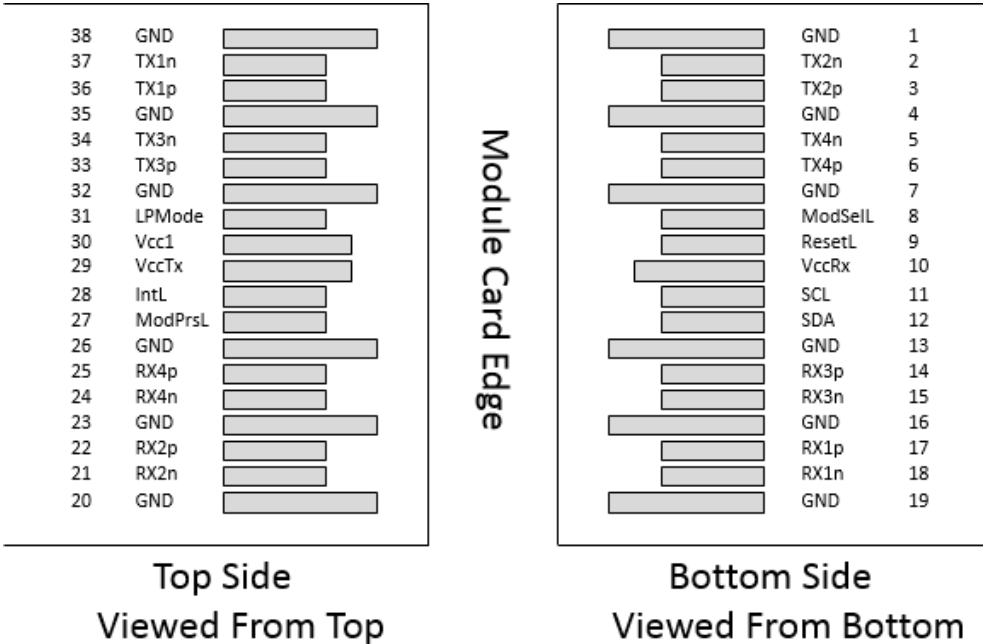

**Dimensions**

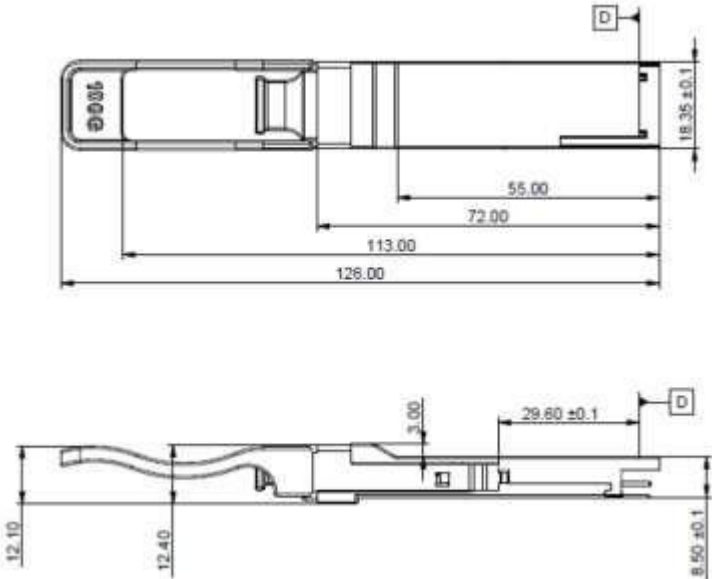

Note: Dimensions are in mm, All Dimensions are 0.2mm unless otherwise specified

## Pin Descriptions

PIN	Logic	Symbol	Name/Description	Note
1		GND	Ground	1
2	CML-I	Tx2n	Transmitter Inverted Data Input	
3	CML-I	Tx2p	Transmitter Non-Inverted Data output	
4		GND	Ground	1
5	CML-I	Tx4n	Transmitter inverted Data Input	
6	CML-I	Tx4p	Transmitter Non-Inverted Data output	
7		GND	Ground	1
8	LVTLL-I	ModSelL	Module Select	
9	LVTLL-I	ResetL	Module Reset	
10		VccRx	+3.3V Power Supply Receiver	2
11	LVC MOS-I/O	SCL	2-Wire Serial Interface Clock	
12	LVC MOS-I/O	SDA	2-Wire Serial Interface Data	
13		GND	Ground	
14	CML-O	Rx3p	Receiver Non-Inverted Data output	
15	CML-O	Rx3n	Receiver Inverted Data output	
16		GND	Ground	1
17	CML-O	Rx1p	Receiver Non-Inverted Data Output	
18	CML-O	Rx1n	Receiver Inverted Data Output	
19		GND	Ground	1
20		GND	Ground	1
21	CML-O	Rx2n	Receiver Inverted Data output	
22	CML-O	Rx2p	Receiver Non-Inverted Data output	
23		GND	Ground	1
24	CML-O	Rx4n	Receiver Inverted Data output	
25	CML-O	Rx4p	Receiver Non-Inverted Data output	
26		GND	Ground	1
27	LVTTL-O	ModPrsL	Module Present	
28	LVTTL-O	IntL	Interrupt	
29		VccTx	+3.3V Power Supply transmitter	
30		Vcc1	+3.3V Power Supply	



31	LVTTL-I	LPMODE	Low Power Mode	
32		GND	Ground	1
33	CML-I	Tx3p	Transmitter Non-Inverted Data Input	
34	CML-I	Tx3n	Transmitter Inverted Data Output	
35		GND	Ground	1
36	CML-I	Tx1p	Transmitter Non-Inverted Data Input	
37	CML-I	Tx1n	Transmitter Inverted Data Output	
38		GND	Ground	1

Notes:

1. GND is the symbol for signal and supply (power) common for QSFP28 modules. All are common within the QSFP28 module and all module voltages are referenced to this potential unless otherwise noted. Connect these directly to the host board signal common ground plane.
2. VccRx, VccI and VccTx are the receiver and transmitter power suppliers and shall be applied concurrently. VccRx, VccI and VccTx may be internally connected within the QSFP28 transceiver module in any combination. The connector pins are each rated for a maximum current of 1000mA.

**Ordering information:**

Model Number	Part Number	Voltage	Temperature
AQSFP28-100G-SR4	OPCW-S40-13-CR	3.3V	0°C to 70 °C

**Note: All information contained in this document is subject to change without notice.**